

Series 4, Induction hob with integrated ventilation system, 60 cm, surface mount without frame PVS611B16E

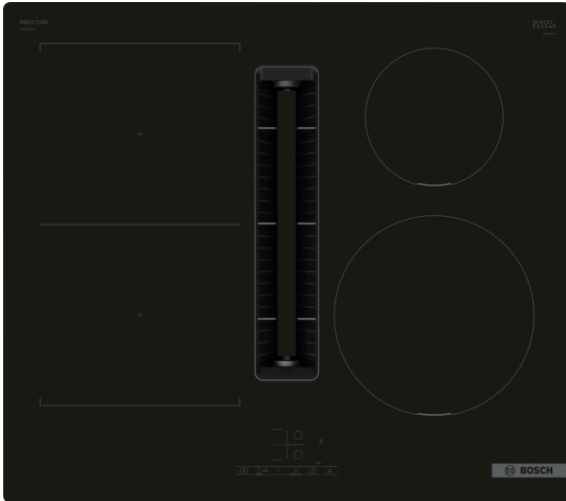

Included accessories

1 x Slider for unducted recirculation
1 x Clean Air Plus odor filter

Optional accessories

HEZ9SE030 Set of 2 pots and 1 pan, HEZ9SE040 4 pieces Set, HEZ9VDKE1 Exhaust kit, HEZ9VDKR0 Recirculation kit 2 L-bow (70cm), HEZ9VDKR1 Recirculation kit S and L-bow (60cm), HEZ9VDSB1 90° flat duct bend horizontal, HEZ9VDSB2 90° flat duct L vertical, HEZ9VDSB3 90° flat duct M vertical, HEZ9VDSB4 90° flat duct S vertical, HEZ9VDSI0 Adapter round-flat, HEZ9VDSI1 90° Adapter round-flat, HEZ9VDSM1 Straight tube 500mm, HEZ9VDSM2 Straight tube 1000mm, HEZ9VDSS1 Connector sleeve (female), HEZ9VDSS2 Flex sleeve (female), HEZ9VEDU0 Acoustics Filter, HEZ9VRCR1 Clean Air Plus odor filter (replacement), HEZ9VRPD1 Plinth Diffusor

The induction hob with integrated ventilation module: combines induction with ventilation technology for perfect results.

- **Integrated ventilation module:** extract steam and cooking odours at the source.
- **Touch Select:** selection of the desired cooking zone and easy setting of the desired power level.
- **Combi Zone:** more flexibility by combining two cooking zones, for roasters and the like.
- **Frameless Design:** the hob surface is slightly elevated, to set your cooking space apart from the worktop.
- **Power Boost:** up to 35% faster heating compared to highest power level.

Technical Data

Product name/family : Cooking zone ceramic
Built-in / Free-standing : Built-in
Energy input : Electric
Min. required niche size for installation (HxWxD) : 223 x 560-560 x 490-490 mm
Width of the appliance : 592 mm
Dimensions : 223 x 592 x 522 mm
Dimensions of the packed product (HxWxD) : 431 x 697 x 672 mm
Net weight : 0.0 kg
Gross weight : 0.0 kg
Residual heat indicator : yes
Location of control panel : Hob front
Basic surface material : Ceramic
Color of surface : Black
Length electrical supply cord : 110.0 cm
Sealed Burners : No
Boost function for pots : All cooking zones
Power of 2nd heating element (kW) : 3.6 kW
Power of 5th heating element (kW) : 1.4 kW
Maximum output air extraction : 500 m³/h
Boost position output recirculating : 595.0 m³/h
Maximum output recirculating air : 441 m³/h
Boost position air extraction : 622 m³/h
Noise level : 69 dB(A) re 1 pW
Odour filter : No
Voltage : 220-240/380-415 V
Frequency : 50-60 Hz
Length electrical supply cord : 110.0 cm
Min. required niche size for installation (HxWxD) : 223 x 560-560 x 490-490 mm
Dimensions : 223 x 592 x 522 mm
Dimensions of the packed product (HxWxD) : 431 x 697 x 672 mm
Net weight : 0.0 kg
Gross weight : 0.0 kg
Included accessories : 1 x Slider for unducted recirculation, 1 x Clean Air Plus odor filter
Delay Shut off modes : 30R_12E min



Series 4, Induction hob with integrated ventilation system, 60 cm, surface mount without frame PVS611B16E

The induction hob with integrated ventilation module: combines induction with ventilation technology for perfect results.

- 60 cm: space for 4 pots

Flexibility of cooking zones

- Combi Zone
: use bigger cookware by connecting two classic cooking zones into one large zone.
- Cooking zone front left: 190 mm, 210 mm, 2.2 KW (max. power 3.7 KW)
- Cooking zone rear left: 190 mm, 210 mm, 2.2 KW (max. power 3.7 KW)
- Cooking zone rear right: 145 mm , 1.4 KW (max power 2.2 KW)
- Cooking zone front right: 210 mm, 2.2 KW (max. power 3.7 KW)

Usage convenience

- Touch Select: control the power with imprinted +/- touch buttons.
- 17 power levels: precisely adapt the heat with 17 power levels (9 main levels and 8 intermediate levels).
- Switch-off timer (on appliance): switches off the cooking zone at the end of the time set (e.g. for boiled eggs).
- Count-down timer: an alarm sounds at the end of the time set (e.g. for pasta).

Time saving & efficiency

- Power Boost for all zones : boil water more quickly thanks to 50% more energy than at the highest standard level.
- QuickStart Function: when switching on, the hob automatically selects the cooking zone with cookware (placed in off-mode).
- Restart Function: in case of unintentional switch-off, restore all previous settings by switching on the hob again within 4 seconds.
- Quick Stop: quickly switch off a cooking zone with one longer touch.

Design

- Frameless: classy, slightly raised installation without metal trim

Safety

- Residual heat indicator (2 stage): indicates which cooking zones are still hot or warm.
- Childproof lock: prevent unintended activation of the hob.
- Main Switch: switch off all cooking zones at the touch of a button.
- Safety switch-off: for safety reasons, heating stops after a preset time without interaction (customizable).

Installation

- Dimensions of the product (HxWxD mm): 223 x 592 x 522
- Required niche size for installation (HxWxD mm) : 223 x 560 x (490 - 490)
- Min. worktop thickness: 16 mm
- Connected load: 7400 W
- PowerManagement Function: limit the maximum power if needed (depends on fuse protection of electric installation).

Accessories

- Clean Air Plus odor filter, Slider for unducted recirculation included
- Installation into 60 cm floor cupboard possible

Integrated ventilation downdraft system

- Induction cooktop with fully integrated high-performance downdraft extractor.
- Suitable for ducted or recirculated extraction configuration (incl. differentiated software modes). Installation accessories for unducted recirculation, among these four Clean Air Plus odour filters and a telescopic slider element, are included in the cooktop. Accessories for other installation options are available, details in the planning notes.
- Aesthetically integrated fully flush air intake design with floating, heat resistant glass ceramics element for free movement and placement of cookware.
- Ventilation system with 3 electronically controlled fan power levels and 1 Boost-/Intensive fan power levels (with automatic revert) via Touch Select user interface:
 - Automatic switch-on of ventilation system when a cooking zone is used.
 - Automatic delayed shut-off after cooking to erase residual odors after cooking (in specific ultra low-noise fan level, 12min in ducted extraction, 30min in recirculated extraction, can be shut-off manually).
 - Fully manual control via Touch Select.
- High-performance, low-noise blower with energy-efficient BLDC-technology. High extraction rates at very low noises with pleasant noise frequencies through psycho-acoustically and aerodynamically optimized interior with enclosed,

- non-visible blower. Highly pressuredrop resistant even with longer and more complex ductings.
- Easy-to-detach and easy-to-clean grease filter and liquid collector unit:
 - - Convenient one-hand removal of unit via floating glass ceramics handle.
 - - Integrated, large-scale, high performance stainless-steel grease filters with 12 filtration layers and one black top layer for enhanced aesthetical integration. Grease filtration efficiency of 94 %.
 - - All parts of the unit are easy-to-clean, fully dishwasher safe and heat resistant.
 - - (Upper) Liquid collector unit with 200ml of capacity for standard accidental spillages or cooking condensate.
 - - Powerful drainage system for spillages that exceed 200ml of liquids.
 - - Liquid safety collector with additional capacity of 700ml for more severe accidental situations. Dishwasher safe. Easily accessible and detachable from below.
 - - Overall capturing capacity of 900ml (200ml + 700ml).
 - - Watertight blower system.
 - Ventilation system performance:
 - - Extraction performance in ducted extraction (according to EN 61591): min. normal setting 330 m³/h , max. normal setting 500 m³/h , max. Boost-/Intensive setting 622 m³/h .
 - - Extraction performance in recirculated extraction (according to EN 61591): min. normal setting 252 m³/h , max. normal setting 441 m³/h , max. Boost-/Intensive setting 595 m³/h.
 - - Noise level in ducted extraction (Sound power level according to EN 60704-3): min. normal setting 61 dB re 1 pW, max. normal setting 69 dB re 1 pW, max. Boost-/Intensive setting 74 dB re 1 pW.
 - - Noise level in recirculated extraction (Sound power level according to EN 60704-3.): min. normal setting 55 dB re 1 pW, max. normal setting 66 dB re 1 pW, max. Boost-/Intensive setting 72 dB re 1 pW.
 - Grease filter efficiency (according to EN 61591) 94 %.
 - Consumption data and energy efficiency (according to Regulation (EU) No 65/2014):
 - - Energy Efficiency Class: B (at a range of energy efficiency classes from A+++ to D).
 - - Fluid Dynamic Efficiency: A .
 - Grease filtration efficiency class: B .
 - - Noise min. normal setting & max. normal setting: 61 dB & 69 dB .
 - For recirculation configuration: 2 x 2 battery of directly integrated, high-performance Clean Air Plus odour filters.
 - - Optimized odor reduction performance for cooking applications with complex odor molecules (e.g. fish).
 - - Large scale filter surface with high odor reduction capabilities.
 - - Anti-pollen functionality: The filter retains an extremely high amount of airborne pollen and deactivates allergens which are retained by the filter.
 - - Lifetime of 6-12 months (non-regenerative).
 - - Low-noise filters with optimized psycho-acoustics.
 - - Easy-to-access and easy-to-remove from above.
 - - Replenishment Clean Air Plus odour filter set HEZ9VRCR1.
 - For ducted extraction configuration: 2 x 2 Battery of directly integrated, high-performance low-noise acoustic filters for significantly lower noise and improved psycho-acoustics.
- Planning notes**
- Suitable for ducted or recirculated extraction installations in 4 different options (unducted, partly and fully ducted recirculation or ducted extraction). Installation accessories for unducted recirculation, among these four Clean Air Plus odour filters and a telescopic slider element, are included in the cooktop. The included accessories allow easy and quick installations and can be planned in all worktop depths ≥60cm. For other types of installation, one of the following accessory kits is recommended:
 - - HEZ9VDKR1 for partly-ducted recirculation in worktops of ≥60cm depth with max. worktop height of 960 mm.

- HEZ9VDKRO for partly-ducted recirculation in worktops of ≥ 70 cm depth with max. worktop height of 960 mm.
- - HEZ9VDKE1 as starter kit for ducted extraction in worktops of ≥ 60 cm depth.
 - To complete the fully ducted extraction or to do any other individual recirculation planning different ducting accessories are available.
 - Planning suggestions:
 - - Installation is possible in island as well as wall oriented configurations.
 - - The product and its accessories comply with the Needle Flame Test (according to IEC 60695-11-5) and the B1/B2 building material class (according to DIN 4102-1).
 - - The max. immersion depth is 223 mm below worktop surface.
 - - The appliance must be freely accessible from below (i.e. for accessing the lower liquid safety collector).
 - - No false floor is necessary below the cooktop with integrated downdraft ventilation system. The drawers and/or shelves in the floor unit must be removable. The backpanel of the floor unit can be kept - only a cut-out for the air outlet is needed (position and size can be taken from the installation instructions).
 - - An installation with unducted recirculation requires a vertical aperture of min. 25mm behind the backpanel of the furniture. Suggested for ideal performance are 50mm.
 - - The minimum worktop thickness is 16 mm for top mounted and flush installed appliances with the standard installation system. Installation in even thinner worktops is also possible with the spare part: content 626792.
 - - The overall appliance weight is 26kg - the bearing capacity and stability, in the case of very thin worktops in particular, must be supported using suitable substructures. The overall appliance weight and the worktop manufacturer's structural integrity specifications are to be taken into account.
 - - For partly ducted and unducted recirculation extraction installations, a return-flow aperture of $\geq 400\text{cm}^2$ is to be respected in the plinth area. The aperture can be realized via outlet grids, lamella grids or subtly shortened plinths depending on the assortment of the kitchen furniture manufacturer.
 - - The air outlet on the backside of the appliance can directly be accessed with a male flat duct element (DN 150).
 - - The pressuredrop resistant blower allows longer and more complex ductings up to 8m with three 90° bows while keeping sufficient performance.
 - - When installing an venting cooktop with ducted extraction and a chimney-vented fireplace, the power supply line of the appliance needs a suitable safety switch. This is not required for configurations in recirculated extraction.
 - - In ducted extraction configuration a one-way flap (or backflow trap) with a maximum opening pressure of 65Pa should be installed.

Series 4, Induction hob with integrated ventilation system, 60 cm, surface mount without frame PVS611B16E

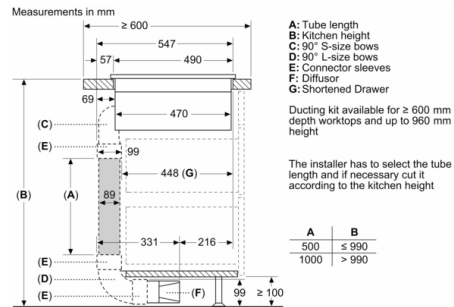
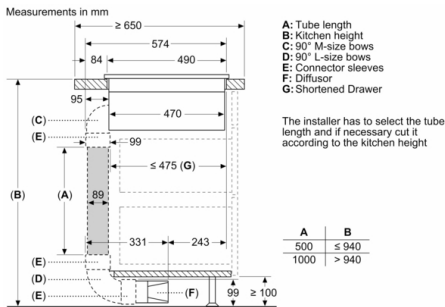
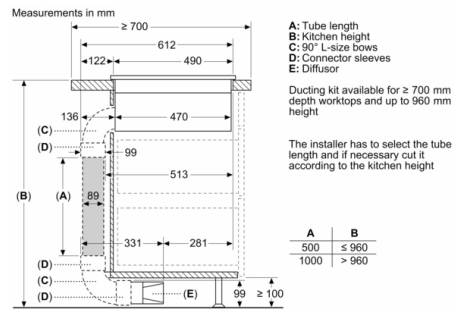
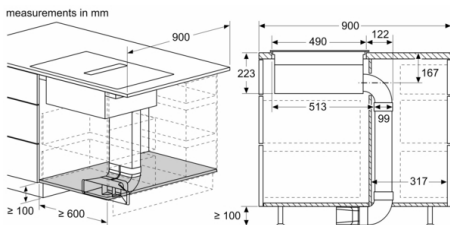

measurements in mm
Front view

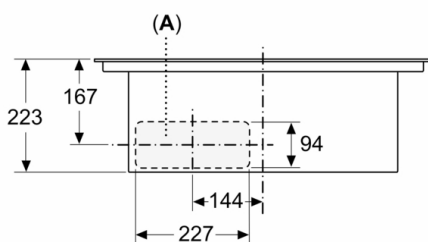

A: Connected directly at the rear

measurements in mm

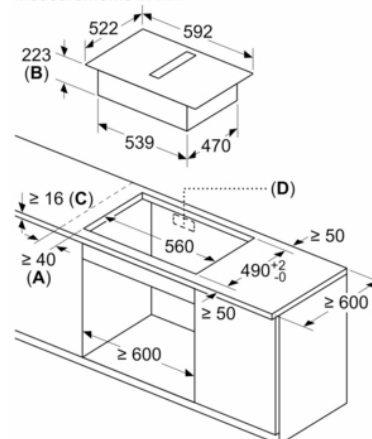

A: Minimum distance from the hob cut-out to the wall

Series 4, Induction hob with integrated ventilation system, 60 cm, surface mount without frame
PVS611B16E

measurements in mm
 Front view

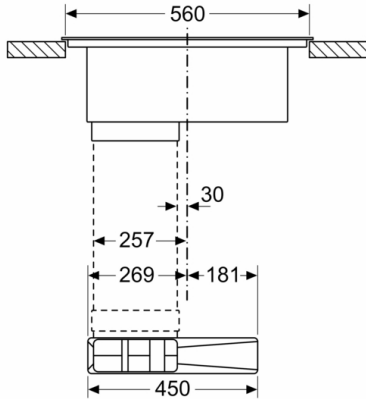

measurements in mm

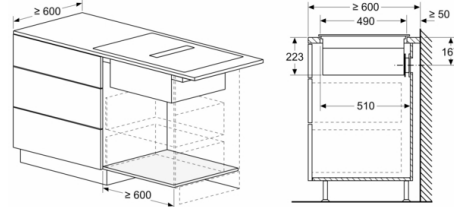

measurements in mm

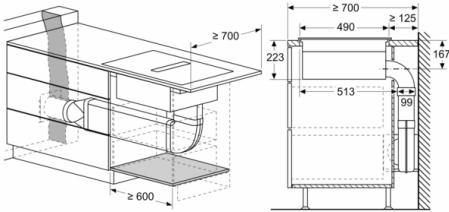

measurements in mm

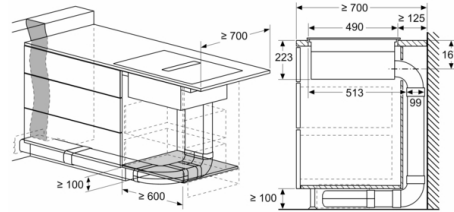

measurements in mm

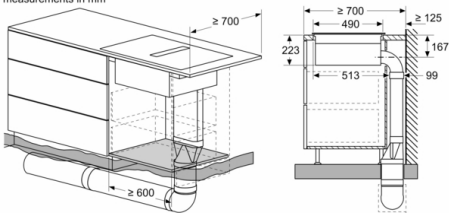

measurements in mm

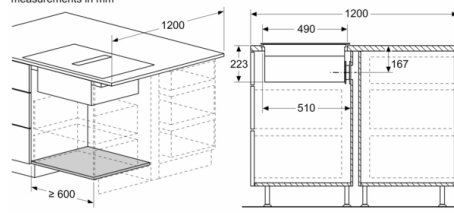

Series 4, Induction hob with integrated ventilation system, 60 cm, surface mount without frame PVS611B16E

Measurements in mm

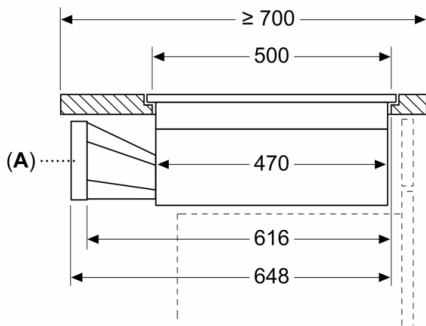

A: Adapter round-flat

Measurements in mm

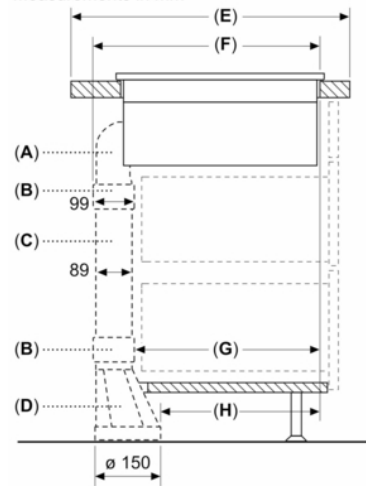

A	E	F	G	H
S-size	≥ 600	547	451	389
M-size	≥ 650	574	475	413

measurements in mm
Front view – unit cut-out
for unducted recirculation

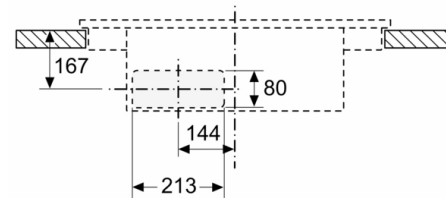

Measurements in mm

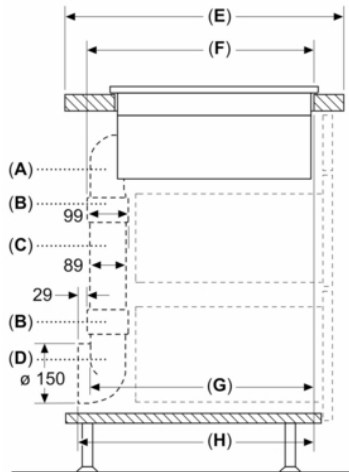

A	E	F	G	H
S-size	≥ 600	547	545	579
M-size	≥ 650	574	569	603

measurements in mm

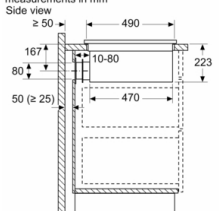

When installing directly at outer walls that are non-insulated ($\mu \geq 0.5 \text{ W/m}^2\text{°C}$), we recommend to use partially or fully ducted recirculation configurations.